

Level Shifter Board

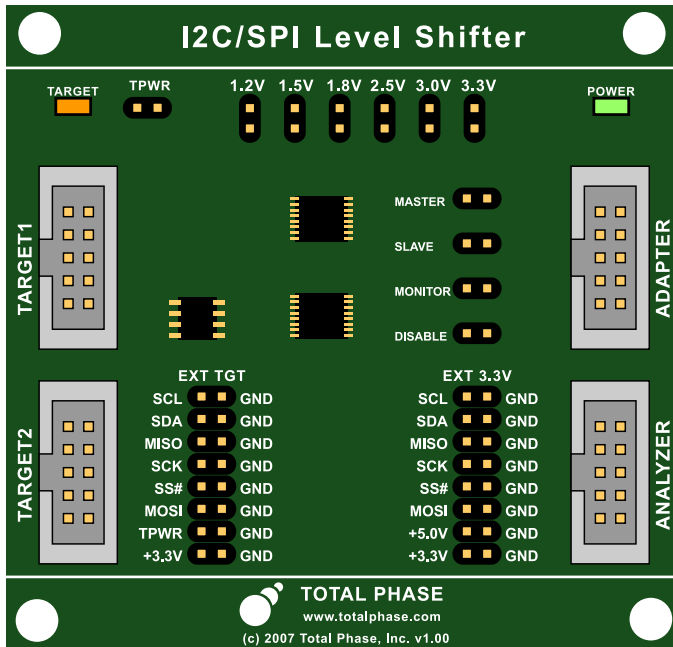

Features

- Level shifting of I²C, SPI, and MDIO signals from 1.2 V to 3.3 V
- I²C speeds of up to 800 kHz
- SPI and MDIO speeds of up to 20 MHz
- Powering downstream devices
- Multiple voltage options

Summary

The Level Shifter Board expands the utility of all of Total Phases I²C, SPI, and MDIO products by allowing developers to communicate, analyze, and power downstream devices of lower logic levels.



Level Shifter
Board



Datasheet v1.00
February 15, 2008

立野電腦 EXT營業部
E-mail : sales@dsp-tdi.com

〒198-0063 東京都青梅市梅郷5-955 TEL.0428-77-7000 FAX.0428-77-7010

URL <http://www.dsp-tdi.com/>

Contents

1 Overview	3
1.1 Features	3
1.2 What's Included	3
2 Hardware Specification	4
2.1 Power Consumption	4
2.2 Speed	4
2.3 I ² C Pull-up Resistors	4
2.4 Leakage Voltage	4
3 Connectors	5
3.1 ADAPTER and ANALYZER	5
3.2 TARGET1 and TARGET2	6
3.3 EXT 3.3V and EXT TGT	7
3.4 Powering the Level Shifter Board	7
3.5 Cross Connecting Aardvark Adapters and/or Cheetah Adapters	8
4 Configuring the Level Shifter	10
4.1 Selecting Shifting Level	10
4.2 I ² C Level Shifting	10
4.3 SPI Level Shifting	11
4.4 MDIO Level Shifting	12
4.5 GPIO Level Shifting	12
5 Legal / Contact	13
5.1 Disclaimer	13
5.2 Life Support Equipment Policy	13
5.3 Contact Information	13

1 Overview

The Level Shifter Board provides embedded systems engineers with an easy and cost-effective method for interfacing Total Phase’s products with lower logic level devices. The Level Shifter Board is capable of down shifting to all standard logic levels from 1.2 V to 3.3 V. Engineers can also choose to power downstream devices.

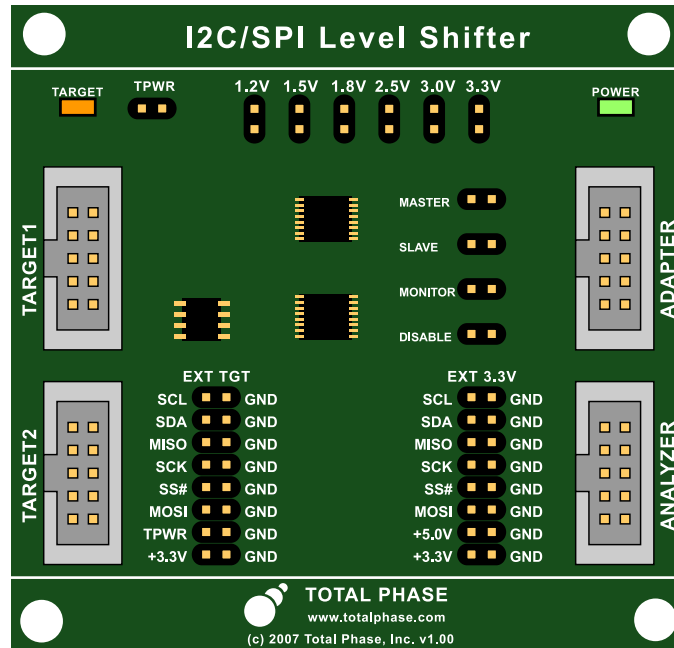

Figure 1: Schematic of the Flash Socket Board

1.1 Features

- Level shifting for I²C , SPI, MDIO, and GPIO signals.
- On-board regulator to specify and power downstream devices to 1.2 V, 1.5 V, 1.8 V, 2.5 V, 3.0 V, and 3.3 V.

1.2 What’s Included

The Level Shifter Board comes complete with:

- (1) Level Shifter Board
- (1) 6.0 inch 10-pin ribbon cable
- (1) 1.5 inch 10-pin ribbon cable
- (3) jumpers for configuration

2 Hardware Specification

2.1 Power Consumption

The power consumption of the Level Shifter Board depends on its configuration. The board will draw approximately 6 mA from the Adapter/Analyzer side when configured to power the target device, and approximately 4 mA when the target is supplying its own power.

The current draw of the Level Shifter Board on the Target side is only applicable when the target device is supplying power to the board. This current draw will be approximately 1 mA.

2.2 Speed

The Level Shifter Board is rated for I²C communication at up to 800kHz.

Maximum SPI and MDIO signaling rates are highly dependent on the specific configuration of the level shifting board and the timing specification of the target device. The Level Shifter Board has been tested to operate at up to 18 MHz when shifting to 1.2 V, and up to 20 MHz when shifting to 3.3 V. When operating at higher speeds, shorter cables are recommended to help maintain signal integrity.

Please note that individual results will vary.

2.3 I²C Pull-up Resistors

The Adapter/Analyzer side will always require pull-up resistors for I²C communication. This is easily accomplished by using the built-in pull-up resistors of either an Aardvark I²C/SPI Host Adapter or Beagle I²C/SPI/MDIO Protocol Analyzer. Additionally, any I²C line that is being used as a digital input line (GPIO) to the Adapter/Analyzer side, must also include a pull-up on the adapter side.

It is recommended that pull-up resistors are always used on the Target side I²C lines. Users may find that they can still communicate properly without these pull-ups, however it is recommended that pull-ups to the target's logic high still be used to ensure that the signal reaches its correct level.

2.4 Leakage Voltage

The Level Shifter Board is known to leak approximately 0.2 V to the Target side, even when configured to not supply power to the target. This is a very weak leakage which is only capable of sourcing approximately 20 μ A of current.

3 Connectors

3.1 ADAPTER and ANALYZER

There are two boxed connectors on the right side (Adapter/Analyzer side) of the Level Shifter Board (Figure 2) which are used to connect the board to an Aardvark I²C/SPI Host Adapter, Cheetah SPI Host Adapter, and/or Beagle I²C/SPI/MDIO Protocol Analyzer. These two connectors are cross-connected, so it does not matter which one is used. In most cases, you will only want to connect a single adapter to the Level Shifter Board at a time.

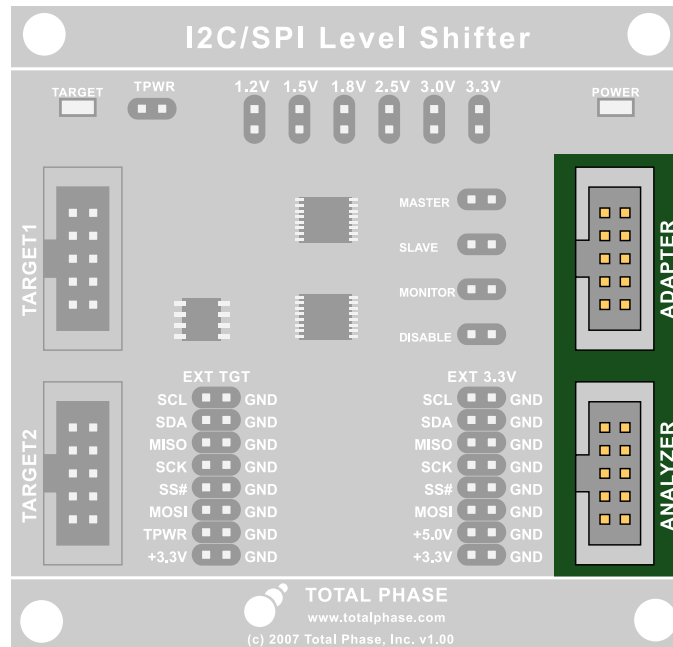

Figure 2: Two boxed connectors for connecting an adapter and/or analyzer to the Level Shifter Board .

The second connector may be used to connect a second host adapter. Examples of these situations are in order to have more slaves or to create a multi-master situation. Alternatively, the second connector can be used to connect a protocol analyzer. For example, an Aardvark adapter or a Cheetah adapter can be connected to the board through the **ADAPTER** connector to program a low voltage memory chip. At the same time, a Beagle I²C/SPI/MDIO Protocol Analyzer can be attached to the **ANALYZER** connector to monitor the bus while the chip is being programmed to ensure that the data on the bus is correct.

The pinout of the two connectors is described in Figure 3.

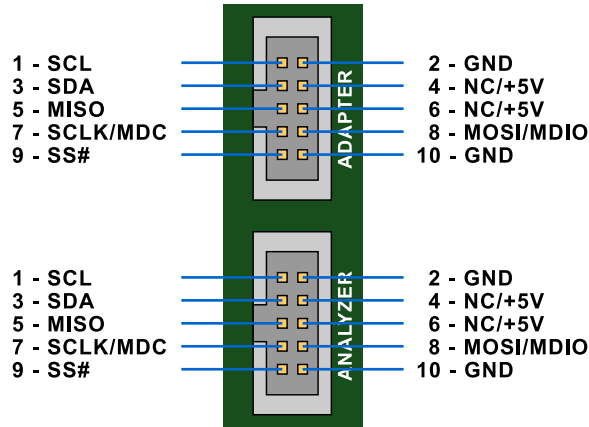

Figure 3: The pinout for the two boxed connectors on the Adapter/Analyzer side of the Level Shifter Board.

3.2 TARGET1 and TARGET2

There are two boxed connectors on the left side (Target side) of the Level Shifter Board (Figure 4) which are used to connect the target bus to the level shifter. The signal lines on these connectors are operating at the voltage levels specified by the user. This level can either be specified on the board through the use of the jumper connectors, or can be determined by the downstream system. These two connectors are cross-connected, so it does not matter which one is used.

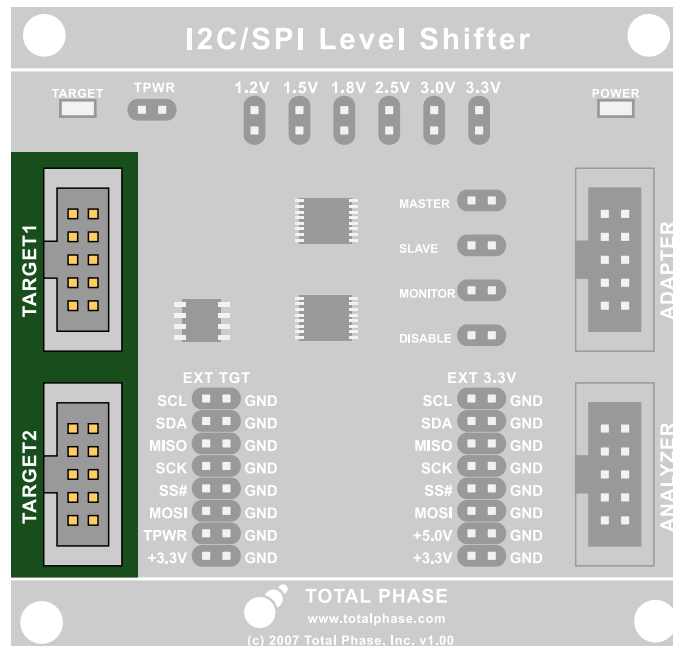

Figure 4: Two boxed connectors for connecting the Level Shifter Board to one or more target buses.

These two boxed connectors have an almost identical pinout to the **ADAPTER** and **ANALYZER**

connector. The only difference is that the 5.0 V pins will have the target's voltage level instead. The pinout of the two connectors is described in Figure 5.

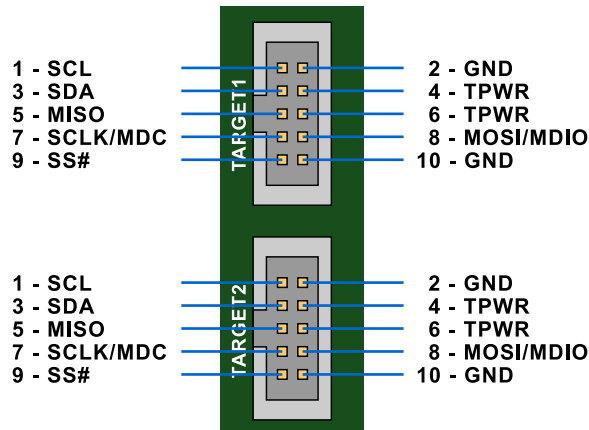

Figure 5: The pinout for the two boxed connectors on the Target side of the Level Shifter Board .

3.3 EXT 3.3V and EXT TGT

All the bus and power signals on the board are also available through two 16-pin headers on the board (Figure 6). The **EXT 3.3V** connector provides the bus signals at the standard signaling levels employed by Total Phase's I²C , SPI, and MDIO products. The **EXT TGT** connector provides the bus and power signals of the downstream device and will be at the voltage level defined by the user. All connections are labeled for the user's convenience.



Figure 6: The External Connectors provides the developer with a quick and easy way to interface or monitor any or all of the Level Shifter Board signals on either the Adapter/Analyzer side or the target side.

3.4 Powering the Level Shifter Board

In order to function properly, both sides of the board must be powered. The Adapter/Analyzer side (the high voltage side) must be powered with 5 V. This can easily be accomplished by using the target power feature of Total Phase's I²C, SPI, or MDIO products when it is connected to the Adapter/Analyzer side of the board. Target power can be enabled via the Rosetta Language Bindings, the Flash Center software, the Aardvark Control Center Software, the Beagle Data Center software, or the Cheetah GUI Software.

When powered-on, the board's green **POWER** LED will be lit.

The Target side (the low voltage side) can optionally be powered by the power already supplied to the Level Shifter Board or by the target device. If powering the Target side by the target device, simply connect the device's power to the TPWR pin on the **EXT TGT** or either one of the **TARGET** boxed connectors (Figure 7).

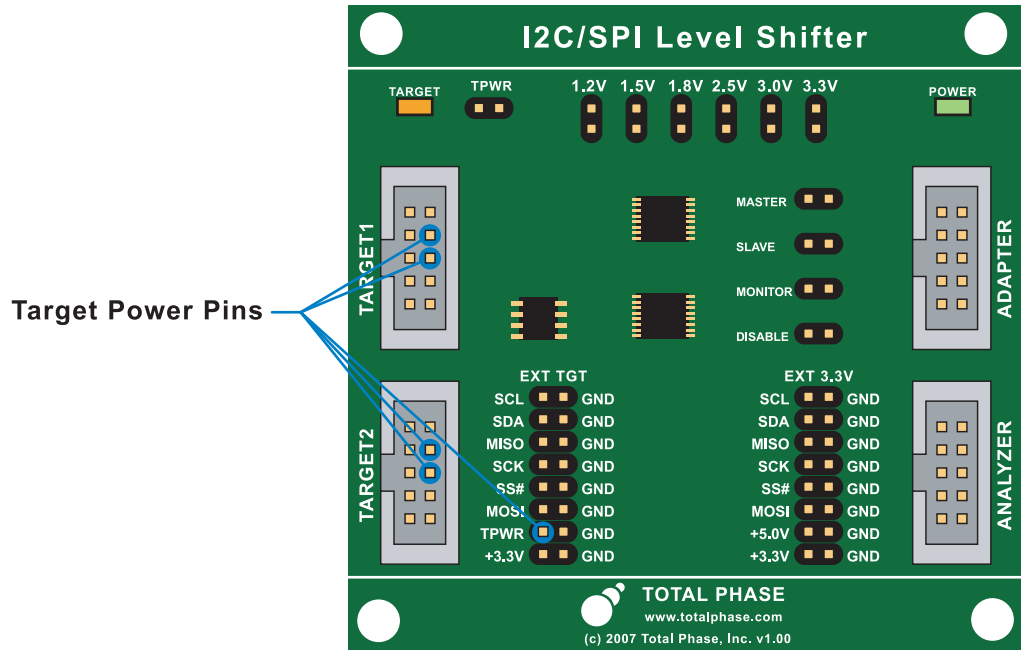

Figure 7: When powering the Target side of the Level Shifter Board, power needs to be supplied to one of these Target power pins.

If powering the Target side by the power already supplied on the board, then a jumper must be placed to enable this feature (Figure 8). Refer to Section 4 for more details.

When the Target side is properly powered, the board's amber **TARGET** LED will be lit.

3.5 Cross Connecting Aardvark Adapters and/or Cheetah Adapters

When cross connecting two adapters, the board must be powered on. Otherwise, results may be unpredictable. If you experience problems, please make sure that the **POWER** LED on the board is lit.

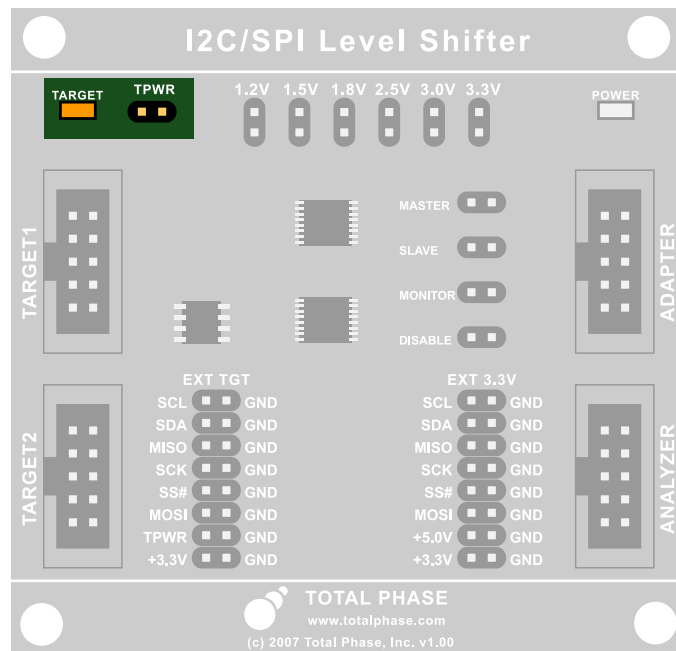

Figure 8: When supplying power from the Level Shifter Board to the target, a jumper needs to be placed on TPWR.

4 Configuring the Level Shifter

4.1 Selecting Shifting Level

There are two options for selecting the Target side logic level.

The first method is to use the power supplied to the Level Shifter Board to power the target device. In this method, the output voltage must be enabled by placing a jumper on the **TPWR** pins. Then a second jumper is used on one of the voltage selection pins illustrated in Figure 9. The pins are clearly labeled with the output voltage that they will set. If no jumper is set on these pins, then it will default to 1.2 V.

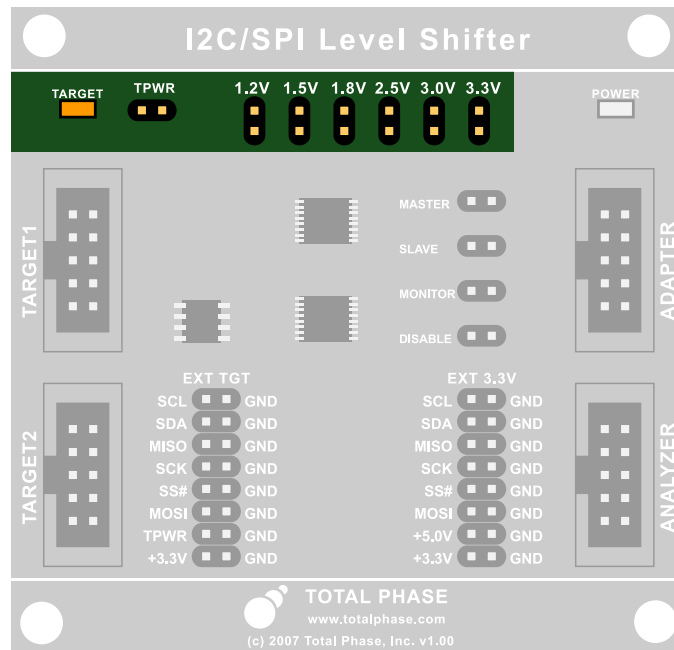

Figure 9: A jumper must be placed on the appropriately labeled header for the desired voltage level. If supplying power from the Level Shifter Board to the target, a jumper needs to be placed on TPWR as well.

The second method is to match the power supplied to the Target side when using a self-powered device/board. When using this option, the logic levels will be set to match the voltage levels applied to TPWR as shown in Figure 7.

In this configuration, the **TPWR** jumper must be removed. Simply connect the power and ground of the target device to the power and ground of the Level Shifter Board Target side. In order to function properly the target's voltage level should not exceed 3.3 V.

4.2 I²C Level Shifting

The I²C level shifting circuit automatically handles the bi-directionality of I²C communication. Simply select the correct logic level (as described previously) and correctly connect the SCL and SDA lines of the master and slave.

4.3 SPI Level Shifting

Unlike I²C, the SPI level shifting logic must be explicitly controlled for direction. The four headers on the right side of the board determine the direction of traffic. Selections are made by placing a jumper on one of the headers. Their uses are described below:

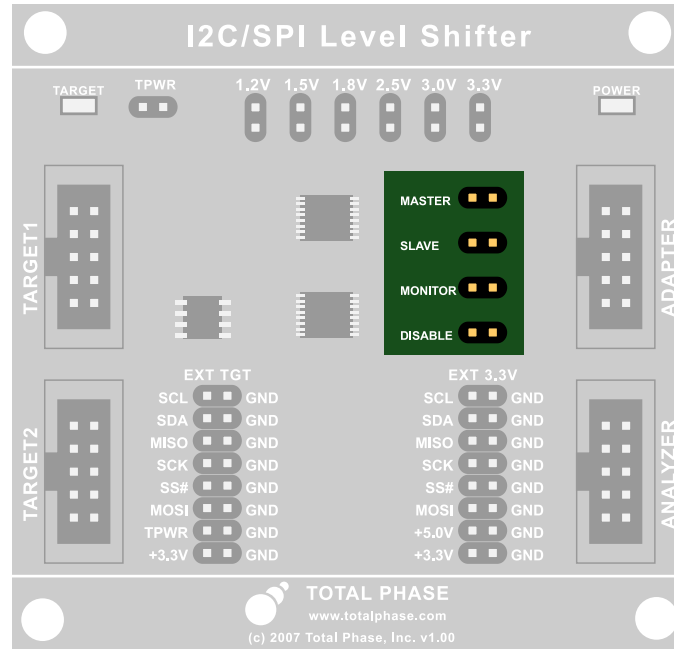

Figure 10: The Level Shifter Board must be configured from the correct mode of operation when using this board to interface with an SPI or an MDIO bus.

- **MASTER:** When selected, will configure the Adapter/Analyzer side of the board to behave as the SPI master. Thus, the SS#, SCK, and MOSI lines will be shifted down to the Target side logic level. The MISO line will be left in its default enabled state, and will be shifted up to the Adapter/Analyzer's logic level.
- **SLAVE:** When selected, will configure the Adapter/Analyzer side of the board to behave as the SPI slave. Thus, the MISO line will be shifted down to the Target side logic level. The SS#, SCK, and MOSI line will be left in their default enabled state, and will be shifted up to the Adapter/Analyzer's logic level.
- **MONITOR:** When selected, will leave all SPI lines in their default enabled state, and will therefore be shifted up to the Adapter/Analyzer side logic level. This option is used in situations where only a Beagle I²C/SPI/MDIO analyzer is plugged into the board, and no SPI adapter is being used.
- **DISABLE:** When selected, will disable all Target side SPI outputs, and set them to a high-impedance state. If no connection is set, the board will default to this state. However, if any of the previous configuration is set, it will take precedence on this one.

It is important to note that for most all cases only one of these connections should be set at a time. Using more than one may cause incorrect SPI operation. The only situation in which

more than one jumper may be used is if the SPI lines are being used for GPIO.

4.4 MDIO Level Shifting

The MDIO signal lines are shared with SPI. It is therefore not possible to bidirectionally shift MDIO signals, as the SPI level shifting does not have the infrastructure for this. However, MDIO *monitoring* of lower logic levels is still possible. Simply place the SPI control jumper on **MONITOR**, and set the Beagle I²C/SPI/MDIO analyzer to monitor MDIO.

4.5 GPIO Level Shifting

GPIO signals may fall on either I²C lines or SPI lines, and each of these situations must be handled separately. When the GPIO lines coincide with the SPI lines, special care must be taken to ensure that the SPI level shifting circuit is configured to the correct direction. The SPI lines are logically broken up into two separate groups: the master-driven lines (SS#, SCK, MOSI) and the slave-driven line (MISO). The direction of each of these groups can be controlled independently, but all signals within a group will be in the same direction.

Placing a jumper on the MASTER header will enable the master-driven lines to down-shift, and the slave-driven line to up-shift. Placing a jumper on the SLAVE header will enable the slave-driven line to down-shift, and the master-driven lines to up-shift. Placing a jumper on the MONITOR header will enable all lines to up-shift. If there is ever a time when a line is configured to be both up-shifting and down-shifting, the down-shift will take precedence. Thus, if you want to use all the SPI lines as digital outputs from the host adapter, simply place jumpers on *both* the MASTER and SLAVE headers.

The I²C lines do not require any directional configuration as it is a bi-directional bus. Each I²C line may go in a different direction, and can also be swapped on the fly.

5 Legal / Contact

5.1 Disclaimer

All of the software and documentation provided in this datasheet, is copyright Total Phase, Inc. (“Total Phase”). License is granted to the user to freely use and distribute the software and documentation in complete and unaltered form, provided that the purpose is to use or evaluate Total Phase products. Distribution rights do not include public posting or mirroring on Internet websites. Only a link to the Total Phase download area can be provided on such public websites.

Total Phase shall in no event be liable to any party for direct, indirect, special, general, incidental, or consequential damages arising from the use of its site, the software or documentation downloaded from its site, or any derivative works thereof, even if Total Phase or distributors have been advised of the possibility of such damage. The software, its documentation, and any derivative works is provided on an “as-is” basis, and thus comes with absolutely no warranty, either express or implied. This disclaimer includes, but is not limited to, implied warranties of merchantability, fitness for any particular purpose, and non-infringement. Total Phase and distributors have no obligation to provide maintenance, support, or updates.

Information in this document is subject to change without notice and should not be construed as a commitment by Total Phase. While the information contained herein is believed to be accurate, Total Phase assumes no responsibility for any errors and/or omissions that may appear in this document.

5.2 Life Support Equipment Policy

Total Phase products are not authorized for use in life support devices or systems. Life support devices or systems include, but are not limited to, surgical implants, medical systems, and other safety-critical systems in which failure of a Total Phase product could cause personal injury or loss of life. Should a Total Phase product be used in such an unauthorized manner, Buyer agrees to indemnify and hold harmless Total Phase, its officers, employees, affiliates, and distributors from any and all claims arising from such use, even if such claim alleges that Total Phase was negligent in the design or manufacture of its product.

5.3 Contact Information

Total Phase can be found on the Internet at <http://www.totalphase.com/>. If you have support-related questions, please email the product engineers at support@totalphase.com. For sales inquiries, please contact sales@totalphase.com.

© 2008 Total Phase, Inc.
All rights reserved.

 立野電腦 EXT營業部
E-mail : sales@dsp-tdi.com
〒198-0063 東京都青梅市梅郷5-955 TEL.0428-77-7000 FAX.0428-77-7010

URL [http : //www.dsp-tdi.com/](http://www.dsp-tdi.com/)