



Datasheet

CoaXPress to CoaXPress over Fiber Signal Converter

Innovative Approach

KAYA Instruments' **CoaXPress to CoaXPress over Fiber Signal Converter** is the industry's first CoaXPress v2.1 signal converter, offering a high-resolution stream interface that converts CoaXPress signals for transmission over fiber. It supports distances up to 80 km in single-mode and up to 300 m in multi-mode. Fiber optic is electrically isolated, hence it does not radiate nor is it susceptible to electromagnetic interference, also eliminates the problems associated with grounding. The fiber cable is not easily tapped, providing more secure communication. The signal converter utilizes a standard CoaXPress over Fiber protocol, ensuring compatibility with standard fiber frame grabbers.

Intelligent Design

The **CoaXPress (CXP) to CoaXPress over Fiber (CoF) Signal Converter** utilizes standard Micro-BNCs converting CXP to CoaXPress over Fiber utilizing standard SFP+ that can support distances up to 80km. The CXP to CoF Signal Converter can provide the camera power using the CoaXPress link with an external power supply. The Signal Converter is able to provide an uplink of up to 12.5 Gbps and downlink up to 41.6 Mbps. A Micro USB port is available for individual link and general information status and firmware updates.

お問い合わせは立野電脳(株) sales@dsp-tdi.com

 **立野電脳** EXT営業部
E-mail : sales@dsp-tdi.com
〒198-0063 東京都青梅市梅郷5-955 TEL.0428-77-7000

URL <https://www.dsp-tdi.com/>

Key Features

- CoaXPress v2.1 support
- CoaXPress over fiber (CXPoF) support
- Support up to 12 G of operation
- Power over CoaXPress with 13 W per link
- Fanless design
- Solves distance limitation of CoaXPress
- Downlink/Uplink of 12.5 Gbps and 41.6 Mbps respectively
- Data rates up to 12.5 Gbps per link
- Extension using Multi-Mode fiber up to 300 m
- Extension using Single-Mode fiber up to 80 km
- CWDM support
- Small mechanical footprint
- Improved power connector
- Rugged design
- Bidirectional CoaXPress communication
- Flexible SFP+ module for fiber optic connection
- Micro-BNC connector for CoaXPress links
- Plug and Play, no configuration required
- Industrial -40 °C to +80 °C operation temperature

Applications

- High speed cameras
- High definition cameras
- Panoramic cameras
- Defense remote systems
- Surveillance
- Sports judgement and analytics

TECHNICAL DATA

General	
Interface standard(s)	CoaXPress v2.1 (CoaXPress 1.1 backward compatible) CoaXPress over Fiber 1.0
Connectors	4x Micro-BNC CoaXPress v2.1 connector 4x SFP+ for CoaXPress over Fiber 1x Micro USB system status port 1x Power 24 V DC input connector
Status LEDs	4x CoaXPress connection status per connector 4x Fiber connection status per connector 1 System status LED
Number of links	4
Line-scan cameras supported	Yes
Supported CXP down-connection speeds	<ul style="list-style-type: none">• 1.25 Gbit/s (CXP-1)• 2.5 Gbit/s (CXP-2)• 3.125 Gbit/s (CXP-3)• 5 Gbit/s (CXP-5)• 6.25 Gbit/s (CXP-6)• 10 Gbit/s (CXP-10)• 12.5 Gbit/s (CXP-12)
Cooling method	Air cooling, passive heatsink
Dimensions	117 mm x 114.5 mm x 23.5 mm (4.6" x 4.5" x 0.92")
Weight	300 g (10.58 oz)
Power Input	24 V DC
Power Consumption	< 11 W (Self consumption not including cameras)
Environmental conditions	
Operating ambient air temperature	-40 °C to +80 °C (-40 °F to +176 °F)
Operating ambient air humidity	10% to 90% RH non-condensing
Storage ambient air temperature	-40 °C to +80 °C (-40 °F to +176 °F)
Storage ambient air humidity	10% to 90% RH non-condensing
Certifications	
Electromagnetic - EMC standards	<ul style="list-style-type: none">• The European Council EMC Directive 2004/108/EC• The United States FCC rule 47 CFR 15
EMC - emission	<ul style="list-style-type: none">• EN 55022:2010 Class B• FCC 47 Part 15 Class B
EMC - immunity	<ul style="list-style-type: none">• EN 55024:2010 Class B• EN 61000-4-3• EN 61000-4-4• EN 61000-4-6
Flammability	PCB compliant with UL 94 V-0
RoHS	Compliant with the European Union Directive 2011/65/EU (ROHS2)
REACH	Compliant with the European Union Regulation No 1907/2006
WEEE	Must be disposed of separately from normal household waste and must be recycled according to local regulations
Ordering Information	
CoaXPress to CoaXPress over Fiber Signal Converter	KY-FEXT-II-D
SFP+ single-mode module, 10 km	KY-SFP-10GLR-31

SFP+ multi-mode module, 300 m	KY-SFP-10GSR-85
CWDM SFP+ module	KY-CWDM-10G-xSP
Fiber cable	KY-FCA-X-XX
CoaXPress Cable	KY-CCA-X-XX
Power supply 24V, 90W	KY_PWR24_PSE(only for Japan)

 **立野電腦** EXT営業部
E-mail : sales@dsp-tdi.com

〒198-0063 東京都青梅市梅郷5-955 TEL.0428-77-7000

URL <https://www.dsp-tdi.com/>

MECHANICAL DRAWINGS

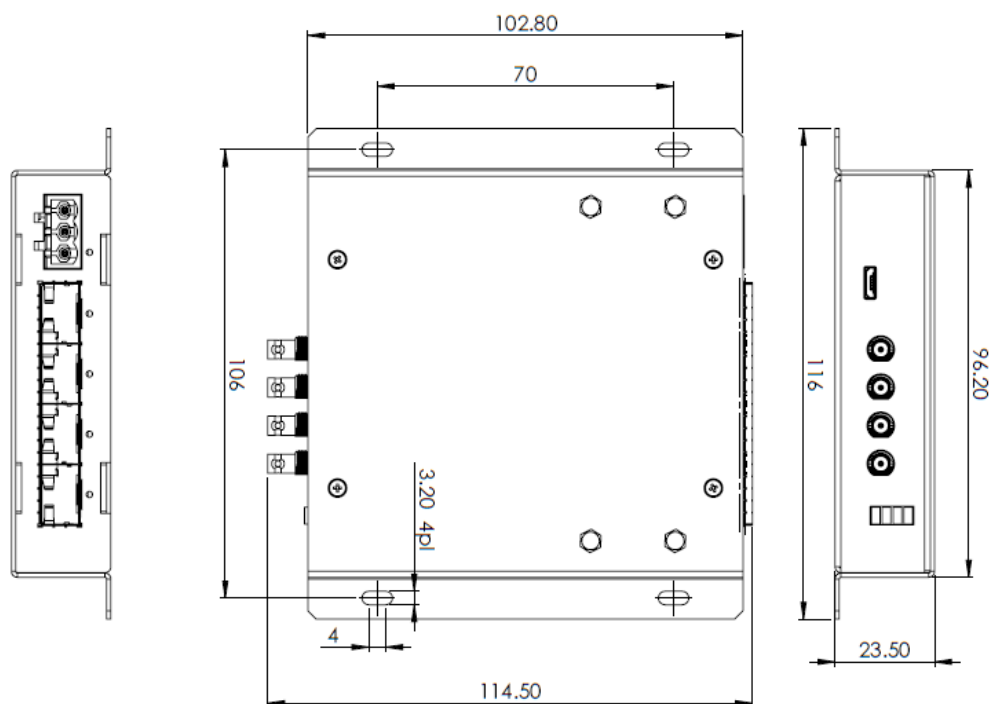

Dimensions are in millimeters.

SYSTEM STRUCTURE

Single camera topology:

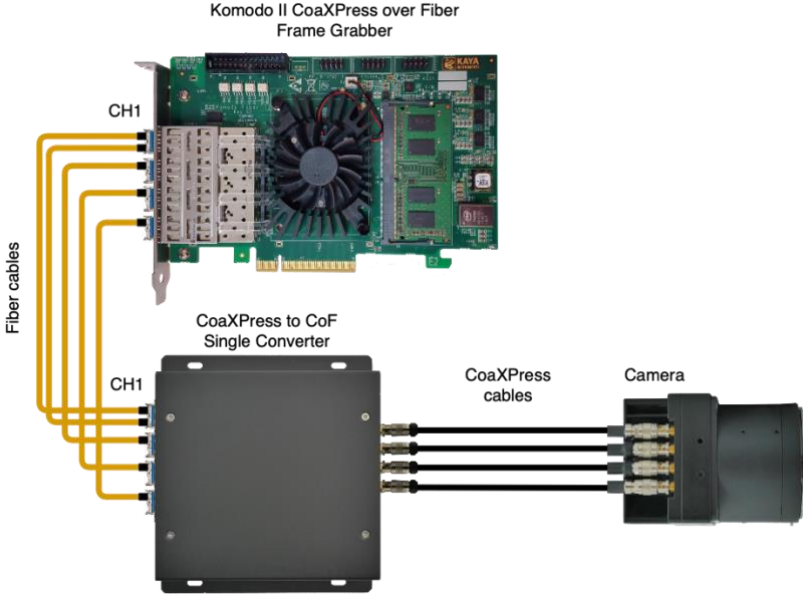

Dual camera topology:

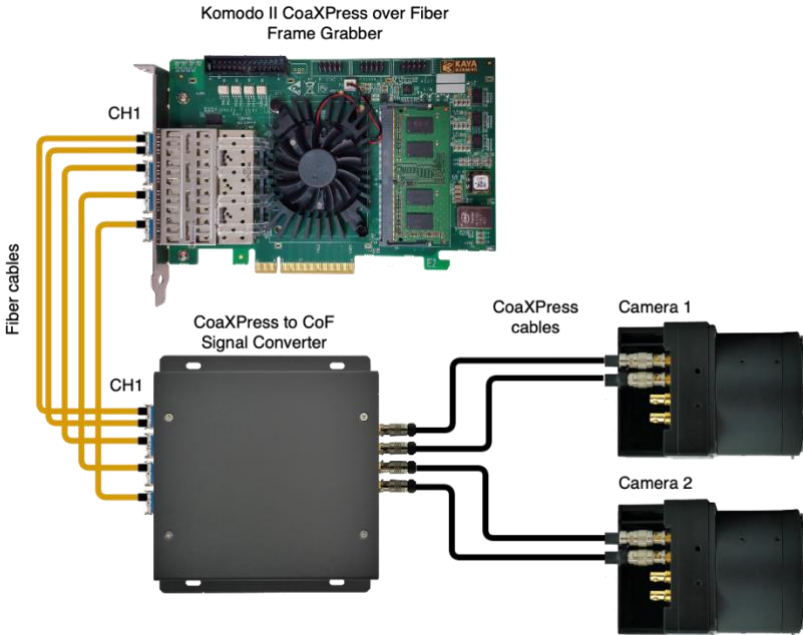

Quad camera topology:

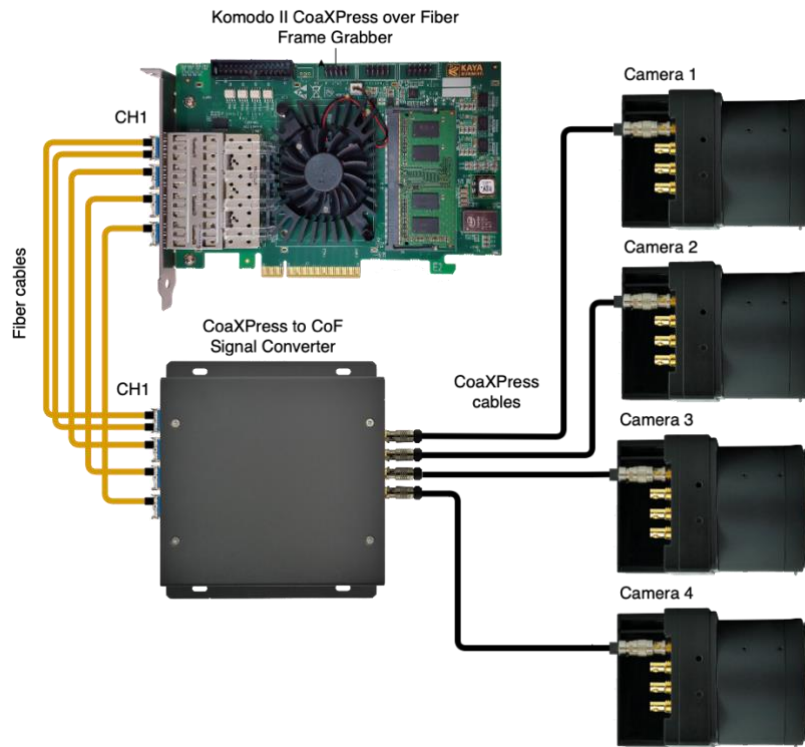

CWDM:

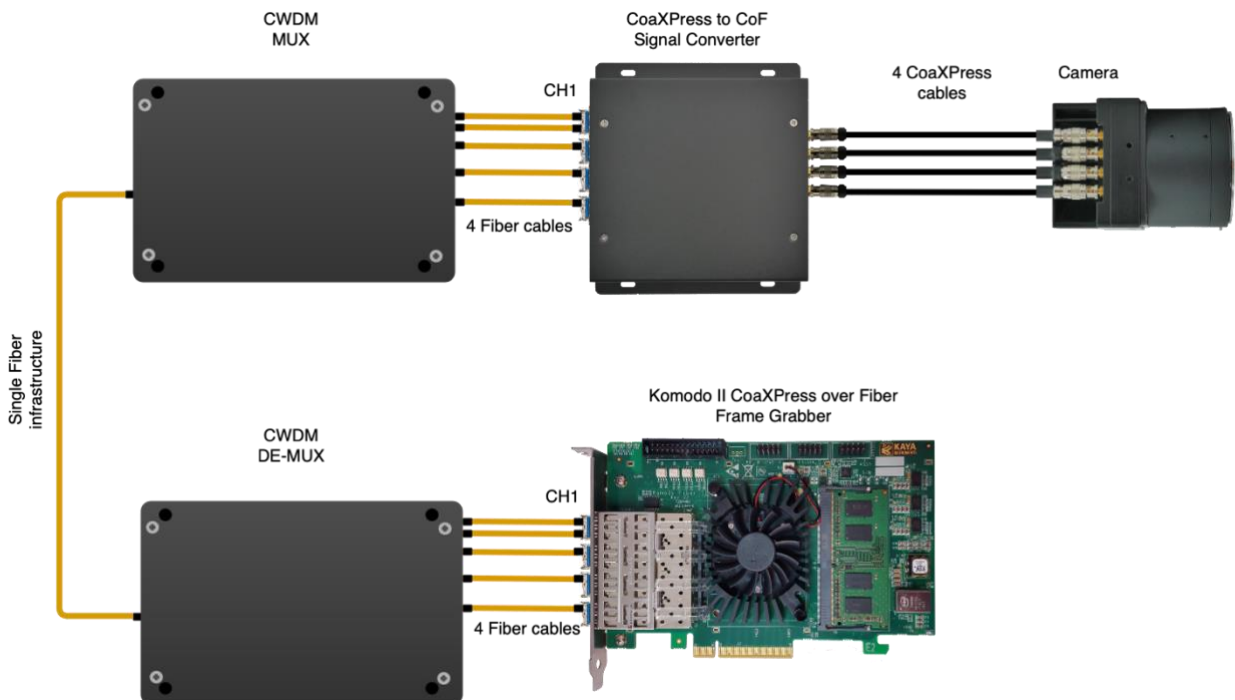

NOTE: Channel 1 (CH1) must have a duplex fiber connection (Or BIDI SFP with single fiber cable) while other channels can have a simplex fiber connection from device side to host.

COMPATIBILITY

KAYA Instruments creates and maintains compatibility and interfaces for the most common and advanced vision image processing libraries and applications. Major support is available for **MVtec Halcon**, **National Instruments' LabVIEW** and **MathWorks' MATLAB**.

Supported vision standards:



Supported vision libraries:



Supported operating systems:



Please check our website for an up-to-date list of other supported libraries and software package

お問い合わせは立野電脳(株) sales@dsp-tdi.com

 **立野電脳** EXT営業部
E-mail : sales@dsp-tdi.com

〒198-0063 東京都青梅市梅郷5-955 TEL.0428-77-7000

URL <https://www.dsp-tdi.com/>

KAYA Instruments

Please feel free to contact our sales team for pricing, availability, documentation or customization at our e-mails – we will be happy to provide assistance and consultation.

Sales Inquiries: info@kayainstruments.com

Technical Support: support@kayainstruments.com

www.KAYAIstruments.com

KAYA Instruments, Inc.
2255 Glades Rd. Suite 324A
Boca Raton, FL 33431
USA

+1 561 698-2899



© 2017 KAYA Instruments, Inc. All rights reserved. KAYA Instruments, the KAYA Instruments Komodo logo, JetCam logo, Predator, Iron and combinations thereof are trademarks of KAYA Instruments, Inc. in the United States and/or other jurisdictions. Microsoft Windows is a registered trademark of Microsoft Corporation. Other names are for informational purposes only and may be trademarks of their respective owners. KAYA Instruments is not liable for harm or damage incurred by information contained in this document.